







# Installation Instructions

## TrekStep™

### Vehicle Application

- Toyota Tundra  
2007 – Current  
Part Number: 75305-15

[www.bestop.com](http://www.bestop.com) - We're here to help! Visit our web site and click on "Ask a Question". Click here for more [Truck Accessories by Bestop](#).

INSTALLATION TIME	SKILL LEVEL		
 <b>1/2 Hour</b>	 <b>1 - Easy</b>		
TOOLS			
 Ratchet	 Extension	 Socket 12 mm, 17 mm and 19 mm	 Allen Wrench 3/16"
 Wrench 12 mm	 Safety Glasses		



**⚠ WARNING** Do not rely in any way on the components of this product to protect against injury or death in the event of an accident. Never operate the vehicle in excess of manufacturer's specifications.

#### **WEAR SEAT BELTS AT ALL TIMES**

Read and follow, precisely, all installation instructions provided when installing product. Failure to do so may result in a poor fit and could place occupants of the vehicle in a potentially dangerous situation.

# TrekStep™ – Installation Instructions

## Parts List and Hardware Identification

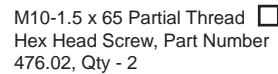
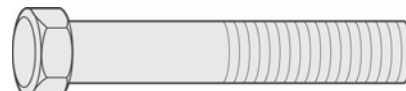
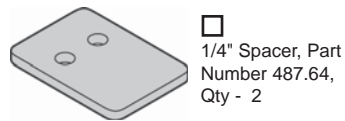
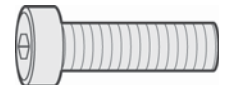
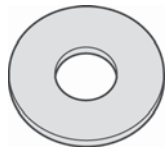
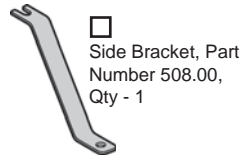
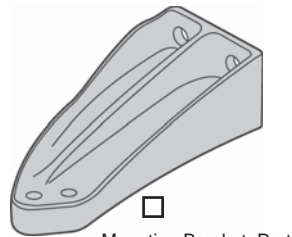
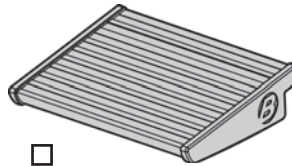
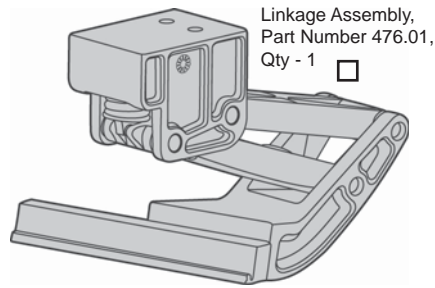

### 2014 – Current Models Only 2013 or earlier skip to Step 7

#### 1 Remove Small Support Bracket

Locate the small support bracket on drivers side of vehicle. Use an M12 socket or wrench to remove the bolts from support bracket. Remove the bracket from the vehicle.

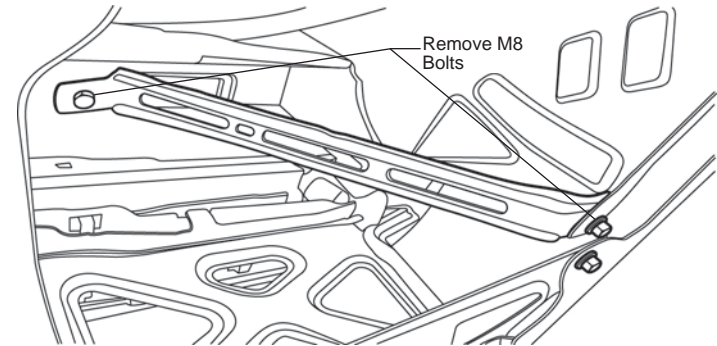

### 2014 – Current Models Only

#### 2 Remove Large Bumper Support Bracket

Locate the large bumper support bracket on drivers side. Use an M13 wrench or socket to remove the 3 bolts that attach bracket to the frame and bumper.

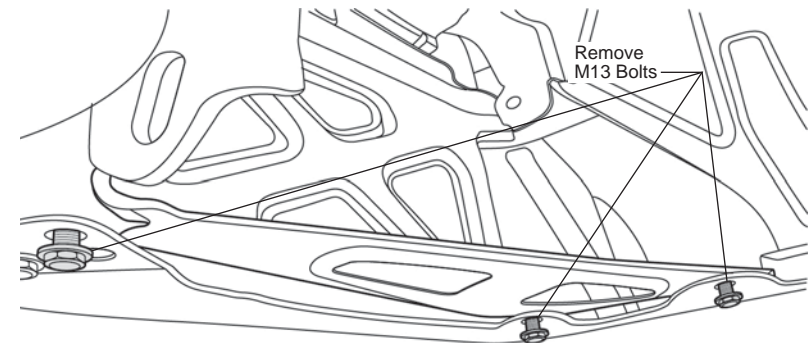

# TrekStep™ – Installation Instructions

## 2014 – Current Models Only

### 3 Remove Plastic Rivet

Remove the plastic rivet in bottom of bumper that is holding the bumper cap.

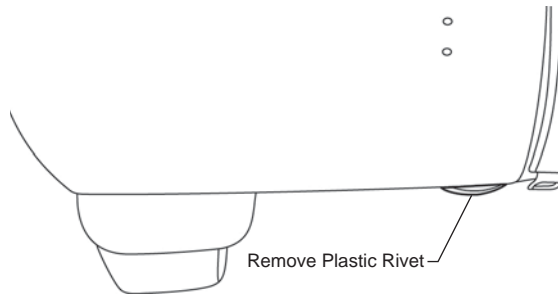

## 2014 – Current Models Only

### 4 Release Bumper Clips

Remove bumper caps from bumper to remove 2 bolts holding bumper bracket. From the bottom side of bumper, use a flat head screwdriver to release clip from bumper slot. Gently pull up on bumper caps from the top until clips come free of bumper.

**NOTE** There are a total of 10 clips that will need to be removed from bumper.

**NOTE** The corner bumper cap will come completely free, the center bumper cap will only need to come up far enough to reach the bumper bracket bolt.

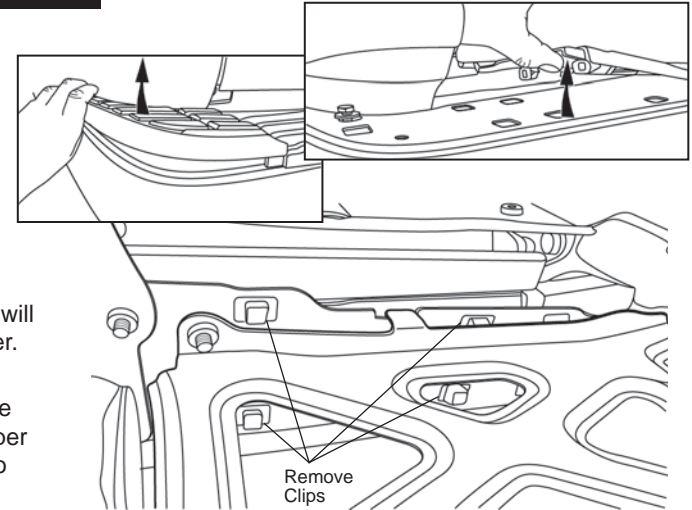

## 2014 – Current Models Only

### 5 Remove Bumper Bracket Bolts

Use an M12 wrench to remove the 2 bumper bracket bolts on top of bumper.

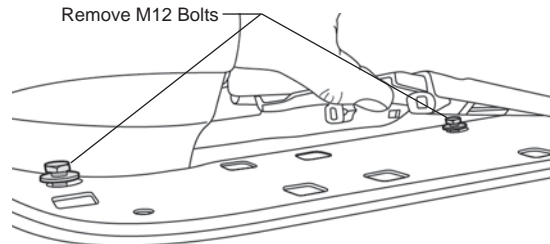

## 2014 – Current Models Only

### 6 Remove Bumper Bracket

Remove the bumper bracket from vehicle. Store the bracket to be used if the Step is removed.

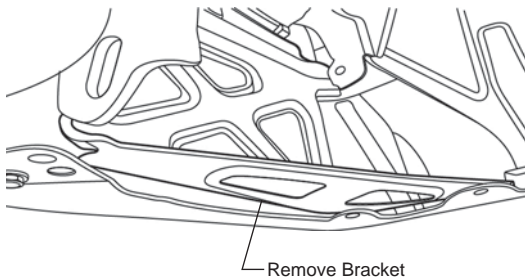

## 7 Locate Rear Bumper Attachment

Locate the rear bumper attachment point on the driver's side of the vehicle.

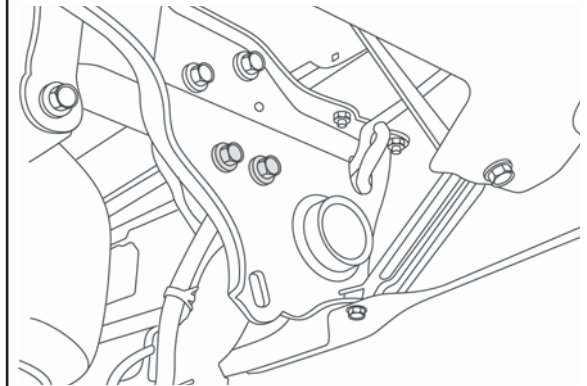

# TrekStep™ – Installation Instructions

## 8 Remove Bumper Fasteners

Remove the bumper fasteners. Set them aside to be reused.

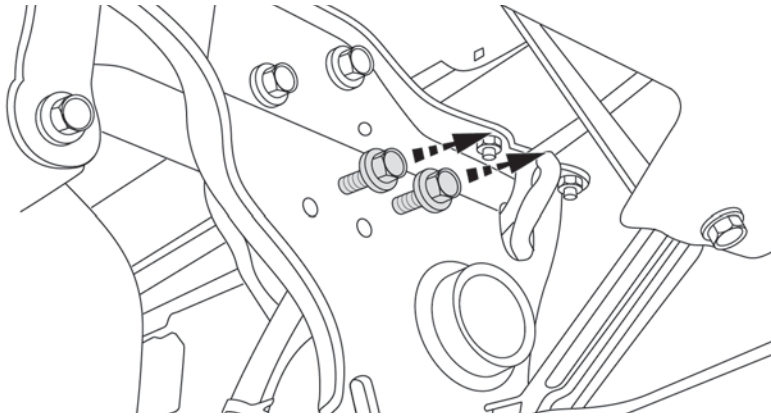

## 9 Install Mounting Bracket

Align the holes in the Mounting Bracket with the holes on the vehicle. Reinstall the fasteners removed in Step 8.

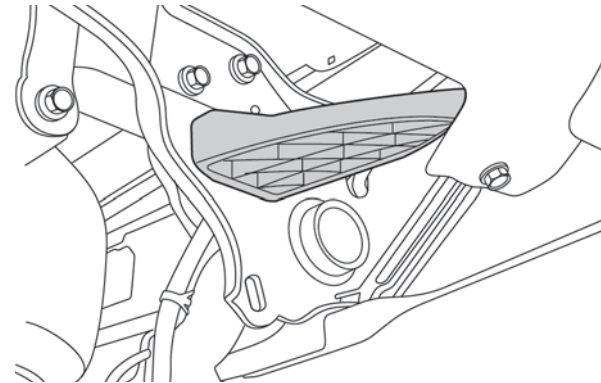

## 10 Install Linkage to Mounting Bracket

Use two (2) M10 x 45 mm Partial Thread Hex Head screws to secure the Linkage to the Mounting Bracket.

**2014 – Current Models:** Secure the slotted end of the Side Bracket to the outside bolt.

**2013 and Earlier Models:** Do not use the Side Bracket

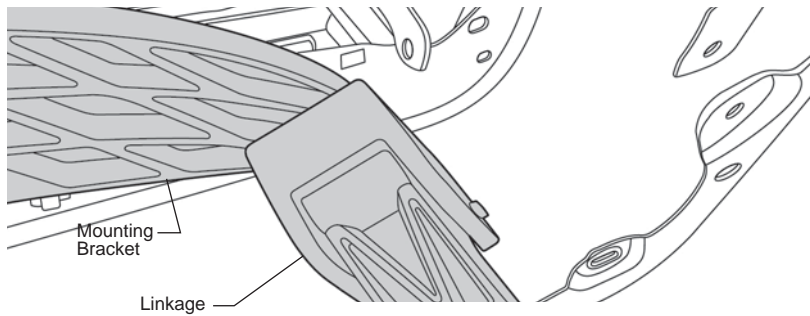

## 2014 – Current Models Only

## 11 Secure Side Bracket to Bumper

Use an M8-1.25 U-Nut and one (1) OE bolt removed in Step 2 to secure the Side Bracket to the bumper.

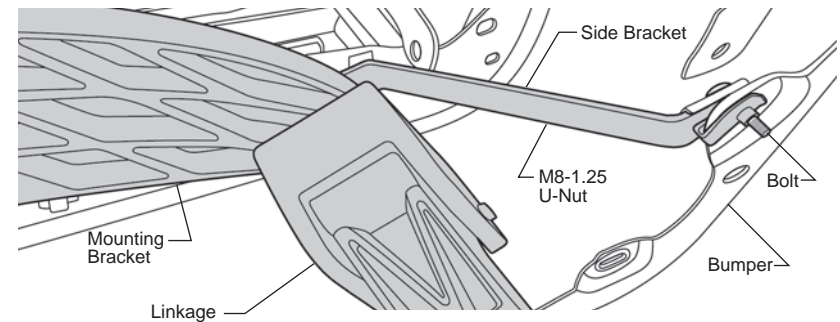

# TrekStep™ – Installation Instructions

**2014 – Current Models Only**

## 12 Reinstall the Small Support Bracket

Reinstall the bracket that was removed in Step 1.

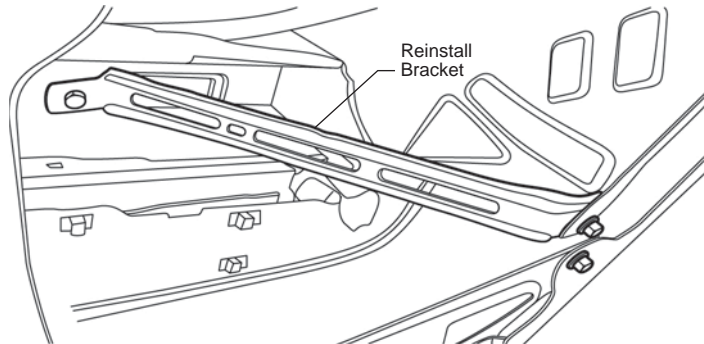

**2014 – Current Models Only**

## 13 Reinstall the Bumper Caps

Line up plastic clips on bumper caps. Press down firmly to lock into place.

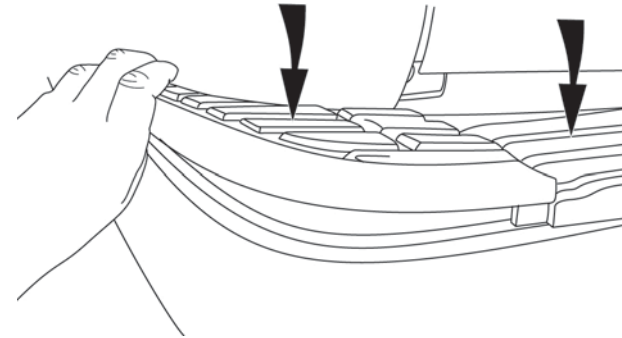

## 14 Install Step

Use the M6-1.0 x 20 Socket Head Cap Screws to mount the Step to the Linkage Assembly.

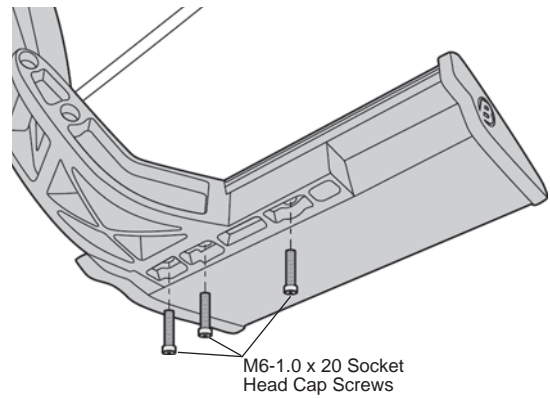

## 15 Step Adjustment

Once the Step is installed on the vehicle, you may adjust it as desired.

If necessary to adjust the height, use the three (3) 1/4" Spacers provided. Remove the M10-15 x 65mm Hex Bolts installed in earlier and place the 1/4" Spacers between the Frame Mount and the Linkage. Reinstall the Hex Bolts.

When the Step is in the desired position tighten all nuts.

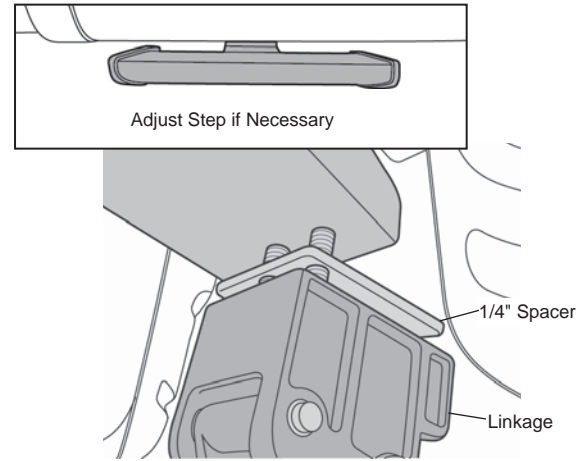

## TrekStep™ – Installation Instructions

### Operation

- The TrekStep™ is foot operated and deploys and retracts with a nudge of your foot.
- To deploy, press down using your left foot, on the forward outside corner of the step pad.
- To retract, gently kick the underside of the step pad.
- Max Load Capacity: 300 lbs.
- Always use appropriate hand holds when stepping up to or down from your vehicle's cargo bed.

### Care and Maintenance

The step pad surface and linkage arms should be washed with mild soap and water using a soft brush or sponge to dislodge any mud, dirt or accumulated road grime. Rinse with fresh water. After it is dry, lubricate the hinge with 3-IN-ONE Oil. To prevent slipping, avoid applying waxes, lubricants or protectants like Armor All® to the step surface.

### Attention!

TrekStep™ SHOULD ALWAYS BE STOWED IN THE RETRACTED POSITION WHEN DRIVING.

## LIMITED WARRANTY

We warrant our product to be free from defects in material and workmanship, for the terms specified below, provided there has been normal use and proper maintenance. This warranty applies to the original purchaser only. All remedies under this warranty are limited to the repair or replacement of any item or items found by the factory to be defective within the time period specified. If you have a warranty claim, first you must call our factory at the number below for instructions. You must retain proof of purchase and submit a copy with any items returned for warranty work. Upon completion of warranty work, if any, we will return the repaired or replaced item or items to you freight prepaid. Damage to our products caused by accidents, fire, vandalism, negligence, misinstallation, misuse, Acts of God, or by defective parts not manufactured by us, is not covered under this warranty.

THE WARRANTY TIME PERIOD IS AS FOLLOWS FOR ALL TrekSteps™ MANUFACTURED BY OUR COMPANY: THREE YEARS / 36,000 MILES FROM DATE OF PURCHASE.

ANY IMPLIED WARRANTIES OF MERCHANTABILITY AND/OR FITNESS FOR A PARTICULAR PURPOSE CREATED HEREBY ARE LIMITED IN DURATION TO THE SAME DURATION AND SCOPE AS THE EXPRESS WRITTEN WARRANTY. OUR COMPANY SHALL NOT BE LIABLE FOR ANY INCIDENTAL OR CONSEQUENTIAL DAMAGE.

Some states do not allow limitations on how long an implied warranty lasts, or the exclusion or limitation of incidental or consequential damages, so the above limitations or exclusions may not apply to you. This warranty gives you specific legal rights, and you may also have other rights which vary from state to state.



For further information or request for warranty work, please contact:  
Bestop Inc. Customer Service  
Toll-Free: (800)845-3567  
Main: (303)465-1755  
E-mail: [csbestop@Bestop.com](mailto:csbestop@Bestop.com)  
Website: [www.Bestop.com](http://www.Bestop.com)