



FRONT RUNNER

**JEEP JK (3 DOOR)
2010 ONWARDS
REAR TRACK**

ENG

TRJW006



INSTALL TIME: 30 mins

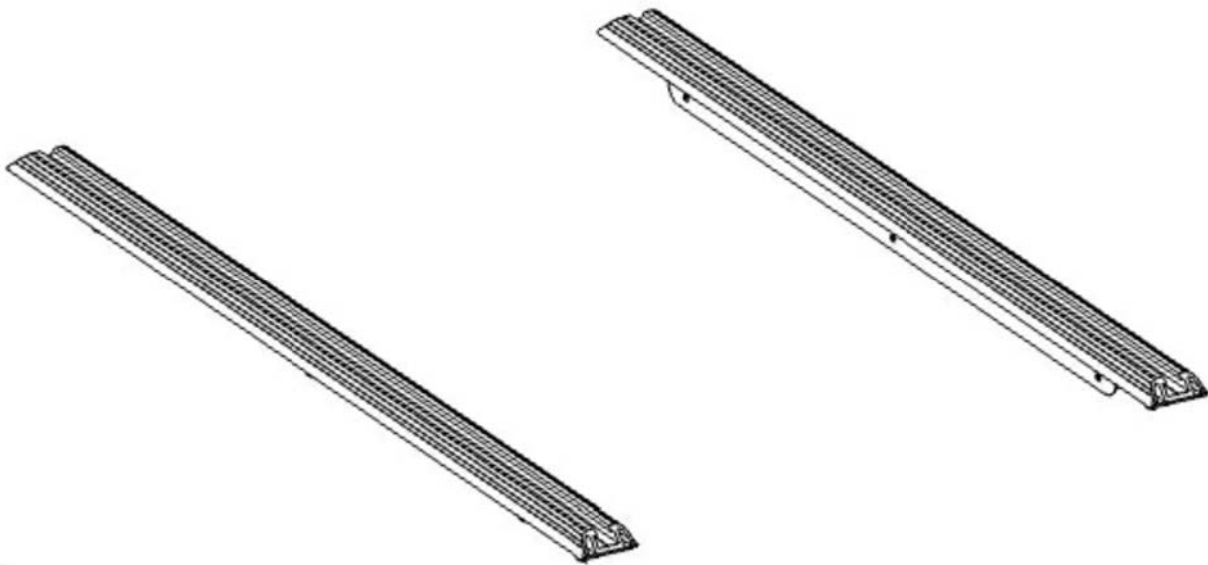

IMPORTANT WARNING!

IT IS CRITICAL THAT ALL FRONT RUNNER PRODUCTS BE PROPERLY AND SECURELY ASSEMBLED AND ATTACHED TO YOUR VEHICLE. IMPROPER ATTACHMENT COULD RESULT IN AN AUTOMOBILE ACCIDENT, AND COULD CAUSE SERIOUS BODILY INJURY OR DEATH TO YOU OR TO OTHERS. YOU ARE RESPONSIBLE FOR ASSEMBLING AND SECURING ALL FRONT RUNNER PRODUCTS TO YOUR VEHICLE, CHECKING THE ATTACHMENTS PRIOR TO USE, AND PERIODICALLY INSPECTING THE PRODUCTS FOR ADJUSTMENT, WEAR, AND DAMAGE. THEREFORE, YOU MUST READ AND UNDERSTAND ALL OF THE INSTRUCTIONS AND CAUTIONS SUPPLIED WITH YOUR FRONT RUNNER PRODUCT PRIOR TO INSTALLATION OR USE. IF YOU DO NOT UNDERSTAND ALL OF THE INSTRUCTIONS AND CAUTIONS, OR IF YOU HAVE NO MECHANICAL EXPERIENCE AND ARE NOT THOROUGHLY FAMILIAR WITH THE INSTALLATION PROCEDURES, YOU SHOULD HAVE THE PRODUCT INSTALLED BY A PROFESSIONAL INSTALLER OR OTHER QUALIFIED PERSONNEL.

1 GET ORGANIZED...

Here is what you are looking at:

Item #	Quantity	Description
1	6	M6X25 COUNTERSUNK ALLEN BOLT
2	2	ROOF TRACK
3	2	RUBBER TRACK LINING
4	2	ANGLE BRACKET
5	6	M6 FLAT WASHER
6	6	M6 NYLOC NUT
7	6	M6 NUT CAP

You will need:

- T40 Torx Wrench
- 4mm Hex Key
- 10mm Flat or Socket Wrench
- Drill Machine
- 6mm (1/4 Inch) Drill Bit
- Silicone Sealant
- Suitable Marking Pen
- Dust Cloth or Blanket
- Pair of Scissors
- Friend

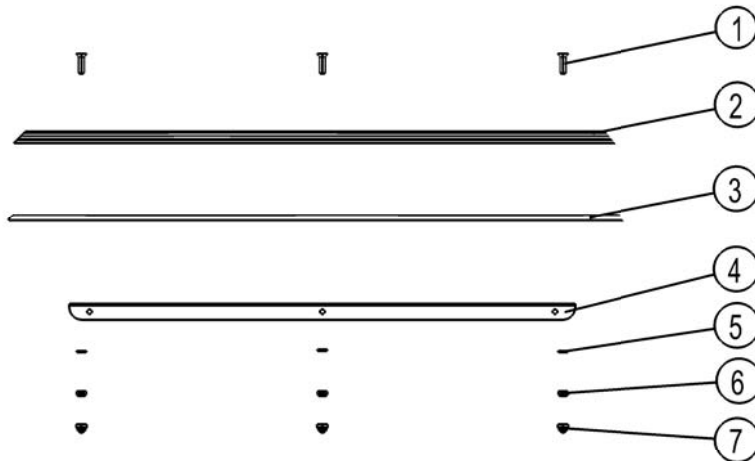

- (A) Familiarize yourself with the parts and then step away from the work area and read through these instructions from beginning to end. Take a moment as a little prep now may save you a lot of time later.

2 INSTALL TRACKS

- (A) Remove the two Front T-top Roofs.

Disconnect the Power Socket and Water Pipe in the back left corner of the vehicle. See picture.



- (B) Using a T40 Torx wrench remove the six Torx Bolts holding the Rear Roof to the vehicle's body.



2 INSTALL TRACKS CONT...

- (C) Using the T40 Torx wrench again, remove the two Torx Bolts, either side of the Front Seat Headrests, holding the rear roof to the vehicle's body.

Grab a friend to help you lift the roof off and place it on a blanket or suitable work surface as not to damage it.



- (D) The Aluminum Tracks ship with the Rubber Linings loosely fitted in place. There are two quick steps to prep the Liners and Tracks. Start by removing the paper backing to expose the glue. Carefully center the holes in the Liner with the holes in the Track and press the Liner into place. Grab your scissors and trim the Liner at the end of each Track so it doesn't overhang. You can cut an angle with the slant of the track, or make a straight cut. You might want to practice first.

- (E) Line up and push the two Tracks against the outside edge of the outer rib on either side of the roof. Line the ends of the Tracks up with the split line between the roof and the rear door section.

Once you are happy with the placement of the Track, mark all the holes using a suitable marking pen.

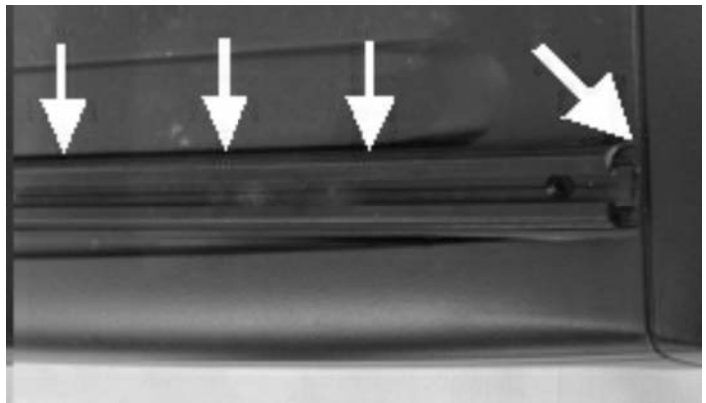

- (F) Remove the Tracks and drill the marked holes using your drill machine and 6mm (1/4 Inch) drill bit. There is NO NEED for a lot of downward pressure. Let the drill do the work - your job is to keep the drill steady - you don't want it slipping across your roof and scratching it!



HINT: Use new sharp drill bits. Also, you don't want to scratch the top of your roof, so keep your workspace clean. If you want to set your tools on the roof, you might want to use a towel or blanket.

2 INSTALL TRACKS CONT...

- (G) Place a silicone bead around the edge of the drilled holes in the roof. Starting at one end, carefully lay down the Tracks, lining up the holes in the Tracks with the holes in the roof. Place some more silicone around the head of the M6 Allen Bolts and insert them through the holes in the Track and roof.

Get a friend to help with the following step. Either you or your friend needs to climb under the roof with the two Angle Brackets, six M6 Nyloc Nuts, six M6 Flat Washers, six M6 nut caps (Items 4,5,6,7) and a 10mm flat/socket wrench.

Line the Angle Brackets up (angle facing inwards) with the bolts and fasten the Brackets to the roof and Track. The person on the outside will have to stop the bolts from turning by holding them with the 4mm Hex Key. Once the brackets are secure place the Nut Caps over the nuts.

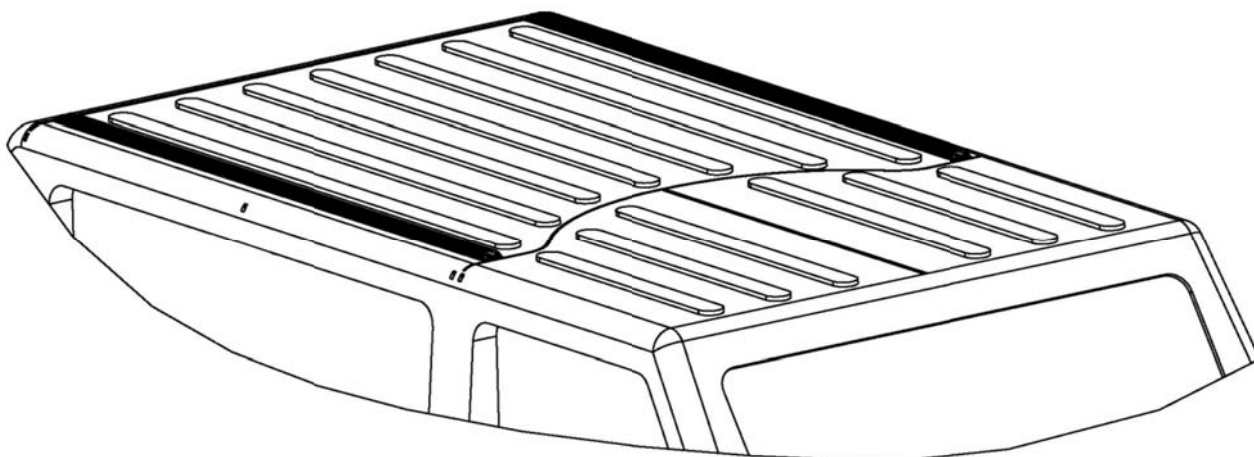

Congratulations, you have completed your installation. Take a step back and admire your work. Good Job!

3 INSTALL OTHER VEHICLE AND RACK ACCESSORIES

- (A) Now's the time to visit your favorite Front Runner dealer in person or online.