



FRONT RUNNER

**LAND ROVER DISCOVERY 3&4
LOAD BAR KIT**

ENG

FALD004 / KRLD027



INSTALL TIME: 60 mins

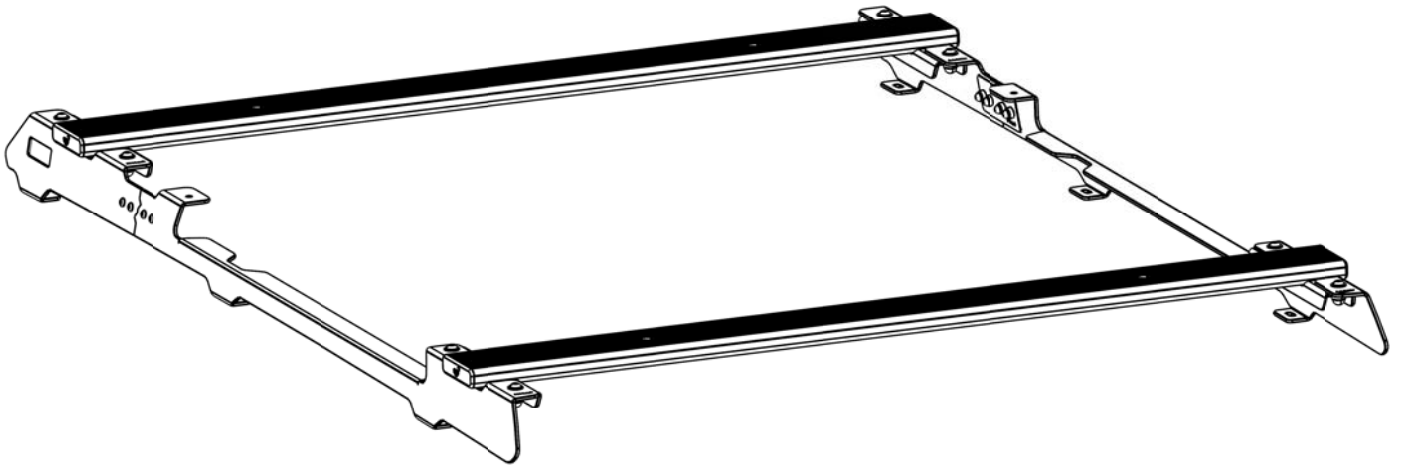

READ ME FIRST:

Thank you for purchasing a Front Runner Load Bar Kit.

Your kit contains:

- 1.) A Load Bar Set
- 2.) A mounting system specific to your vehicle

This document will help you fit the Load Bars to your specific vehicle.

IMPORTANT WARNING!

IT IS CRITICAL THAT ALL FRONT RUNNER PRODUCTS BE PROPERLY AND SECURELY ASSEMBLED AND ATTACHED TO YOUR VEHICLE. IMPROPER ATTACHMENT COULD RESULT IN AN AUTOMOBILE ACCIDENT, AND COULD CAUSE SERIOUS BODILY INJURY OR DEATH TO YOU OR TO OTHERS. YOU ARE RESPONSIBLE FOR ASSEMBLING AND SECURING ALL FRONT RUNNER PRODUCTS TO YOUR VEHICLE, CHECKING THE ATTACHMENTS PRIOR TO USE, AND PERIODICALLY INSPECTING THE PRODUCTS FOR ADJUSTMENT, WEAR, AND DAMAGE. THEREFORE, YOU MUST READ AND UNDERSTAND ALL OF THE INSTRUCTIONS AND CAUTIONS SUPPLIED WITH YOUR FRONT RUNNER PRODUCT PRIOR TO INSTALLATION OR USE. IF YOU DO NOT UNDERSTAND ALL OF THE INSTRUCTIONS AND CAUTIONS, OR IF YOU HAVE NO MECHANICAL EXPERIENCE AND ARE NOT THOROUGHLY FAMILIAR WITH THE INSTALLATION PROCEDURES, YOU SHOULD HAVE THE PRODUCT INSTALLED BY A PROFESSIONAL INSTALLER OR OTHER QUALIFIED PERSONNEL.

1 GET ORGANIZED...

Here is what you are looking at: Please note that only the right hand side's components have been shown and that not all the fasteners received will be used.

Item #	Quantity	Description
1	14	M6 NUT CAP
2	6	M6 x 20 HEX BOLT
3	6	M6 SPRING WASHER
4	6	M6 x 19 FLAT WASHER
5	2	FRONT FOOT RAIL - 1 LEFT, 1 RIGHT
6	8	M6 x 16 BUTTON HEAD BOLT
7	8	M6 FLAT WASHER
8	8	M6 NYLOC NUT
9	2	REAR FOOT RAIL - 1 LEFT, 1 RIGHT

You will need:

- 13 mm Flat and Socket Wrench
- 10 mm Flat and Socket Wrench
- 4 mm Hex Key
- Ladder
- Measuring Tape
- Small Flat Screw Driver
- T27 Torx Wrench
- Friend

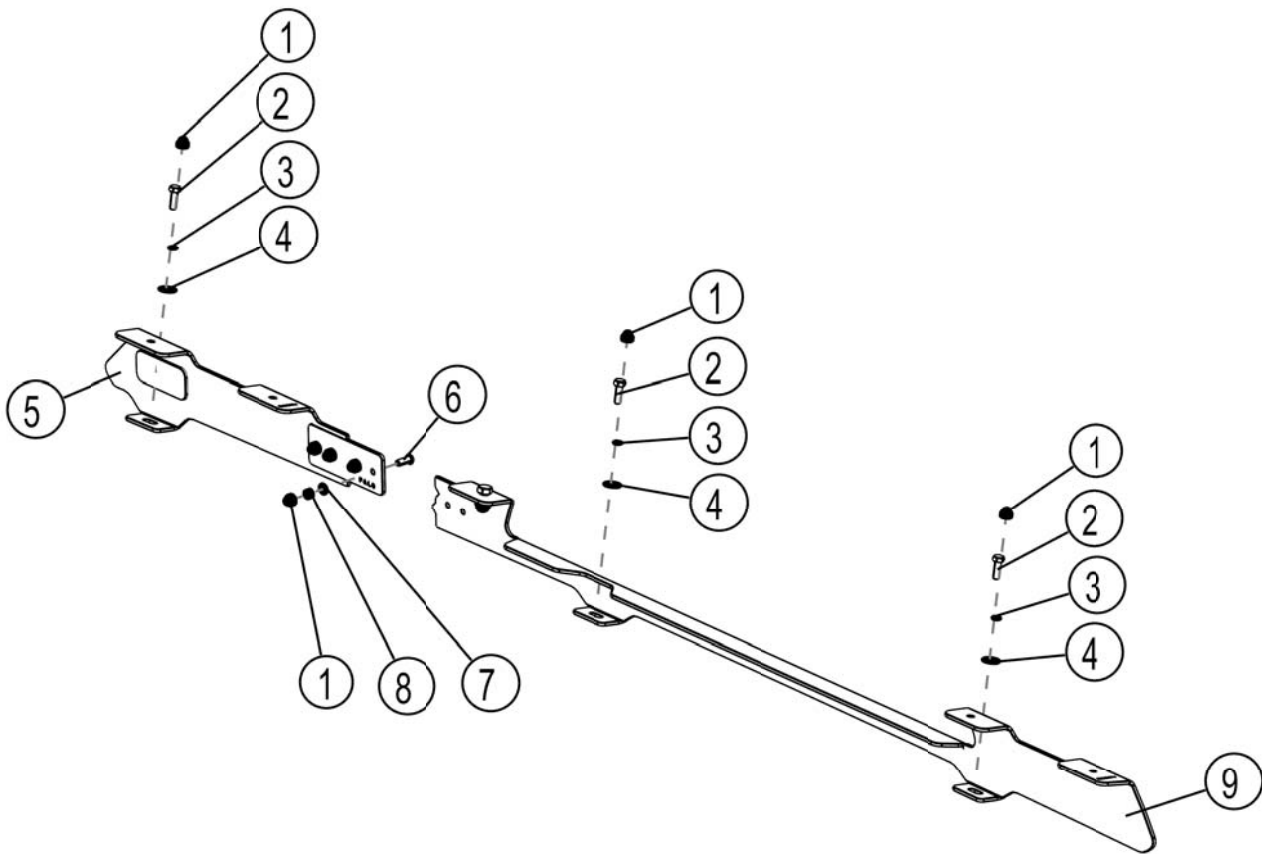

(A) Familiarize yourself with the parts and then step away from the work area and read through these instructions from beginning to end. Take a moment as a little prep now may save you a lot of time later.

2 FIT THE FOOT RAILS

- (A) Using your Torx Wrench, loosen and remove the two original tracks if fitted. If your vehicle did not come with these tracks, refer to Step 2C.



- (B) Loosely join the Front and Rear Foot Rails together using the M6 x 16 Button Head Bolts, M6 Flat Washers and M6 Nyloc Nuts (Items 6, 7, 8) supplied.



Only complete Step 2C if your vehicle did not come fitted with the original tracks referred to in Step 2A.

- (C) Remove the rear section of ditch moulding from the vehicle's roof. Place the assembled Foot Rails onto the vehicle (Product sticker goes to the front and outside of the vehicle), lining up the mounting holes in the Foot Rail with the mounting holes in the vehicle's roof. Loosely fasten the front and rear mounting feet of the Foot Rail to the vehicle using the M6 x 20 Hex Bolts, M6 x 19 Flat Washers and M6 Spring Washers (Items 2, 3, 4) supplied.

Place the ditch moulding next to the Foot Rails, lining the ditch moulding up front to rear with its original position. Mark the position (front and rear) of the three mounting feet onto the ditch moulding. Remove the foot rail and ditch moulding. Cut the ditch moulding 5 mm in from each of your markings and discard the pieces where the mounting feet sit. Reposition the ditch moulding pieces in their original position, leaving gaps where the Foot Rails mounting feet are positioned. Continue to Step 2D.

2 FIT THE FOOT RAILS

- (D) Place the assembled Foot Rails onto the vehicle lining up the mounting holes in the Foot Rails with the mounting holes in the roof. The product sticker must go towards the front of the vehicle and face outwards. Starting from the front, loosely fasten the Foot Rail to the vehicle using the M6 x 20 Hex Bolts, M6 x 19 Flat Washers and M6 Spring Washers (Items 2, 3, 4) supplied. Line up the joint from Step 2B and fasten. Push the Foot Rails towards the rear of the vehicle and tighten all bolts securing the Foot Rail to the vehicle. Place a M6 Nut Cap (Item 1) over each of the Hex Bolts securing the Foot Rails to the vehicle and the Nyloc Nuts to fasten the Joiner plates.

Product Sticker



3 FIT THE LOAD BARS

- (A) Referring to the Fitting Instruction received with your Load Bar Adapters (Document RRAC083), fit the Load Bars to the Foot Rails in the positions as shown below.

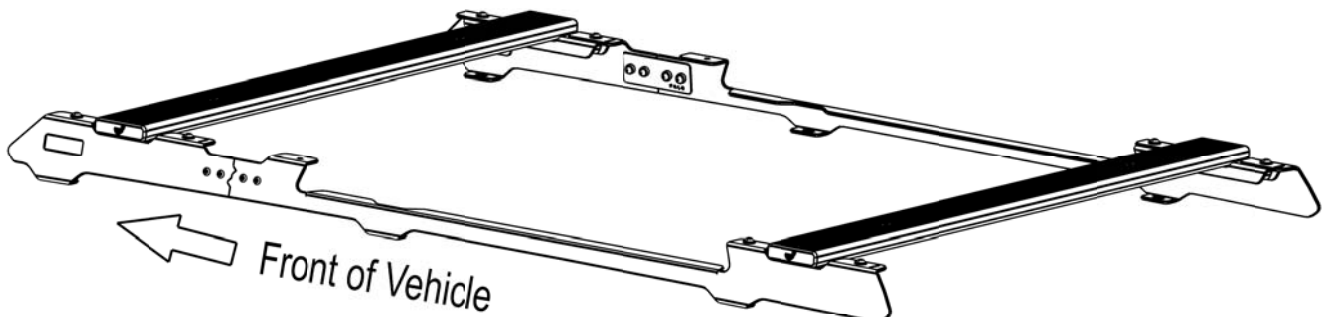

- (B) Congratulations, you have completed your installation. Take a step back and admire your work. Good Job!