



**FRONT RUNNER**

**RENAULT KOLEOS  
SLIMLINE II RACK  
( 1255MM X 1560MM )**

**ENG**

KRRK001T



**INSTALL TIME: 45 Mins**

# START HERE

## READ ME FIRST

Thank you for purchasing a Front Runner Slimline II Rack.

This Roof Rack consists of a kit that contains:

1. A Slimline II Tray
2. A mounting system specific to your vehicle

Before you start, take a moment and open all your boxes and gather the assembly instructions for the various components.

This document will guide you through the assembly of the various mounting system components and assist you in fitting the Slimline II Tray to your specific vehicle.

### IMPORTANT WARNING!

IT IS CRITICAL THAT ALL FRONT RUNNER PRODUCTS BE PROPERLY AND SECURELY ASSEMBLED AND ATTACHED TO YOUR VEHICLE. IMPROPER ATTACHMENT COULD RESULT IN AN AUTOMOBILE ACCIDENT, AND COULD CAUSE SERIOUS BODILY INJURY OR DEATH TO YOU OR TO OTHERS. YOU ARE RESPONSIBLE FOR ASSEMBLING AND SECURING ALL FRONT RUNNER PRODUCTS TO YOUR VEHICLE, CHECKING THE ATTACHMENTS PRIOR TO USE, AND PERIODICALLY INSPECTING THE PRODUCTS FOR ADJUSTMENT, WEAR, AND DAMAGE. THEREFORE, YOU MUST READ AND UNDERSTAND ALL OF THE INSTRUCTIONS AND CAUTIONS SUPPLIED WITH YOUR FRONT RUNNER PRODUCT PRIOR TO INSTALLATION OR USE. IF YOU DO NOT UNDERSTAND ALL OF THE INSTRUCTIONS AND CAUTIONS, OR IF YOU HAVE NO MECHANICAL EXPERIENCE AND ARE NOT THOROUGHLY FAMILIAR WITH THE INSTALLATION PROCEDURES, YOU SHOULD HAVE THE PRODUCT INSTALLED BY A PROFESSIONAL INSTALLER OR OTHER QUALIFIED PERSONNEL.

1

## ASSEMBLE YOUR SLIMLINE II RACK

REFER TO SLIMLINE II TRAY UNIVERSAL ASSEMBLY INSTRUCTION (DOCUMENT RRSTUNI)

2

## FIT THE STRAP-ON FEET

REFER TO STRAP-ON FOOT & STRAP-ON FOOT SPACER ASSEMBLY INSTRUCTIONS (DOCUMENTS FAG0002 & FASG002)

- (A) With your Rack in the upside down position (Product sticker should be upside down), fit the Strap-on Feet to your Slimline II Tray as illustrated below.

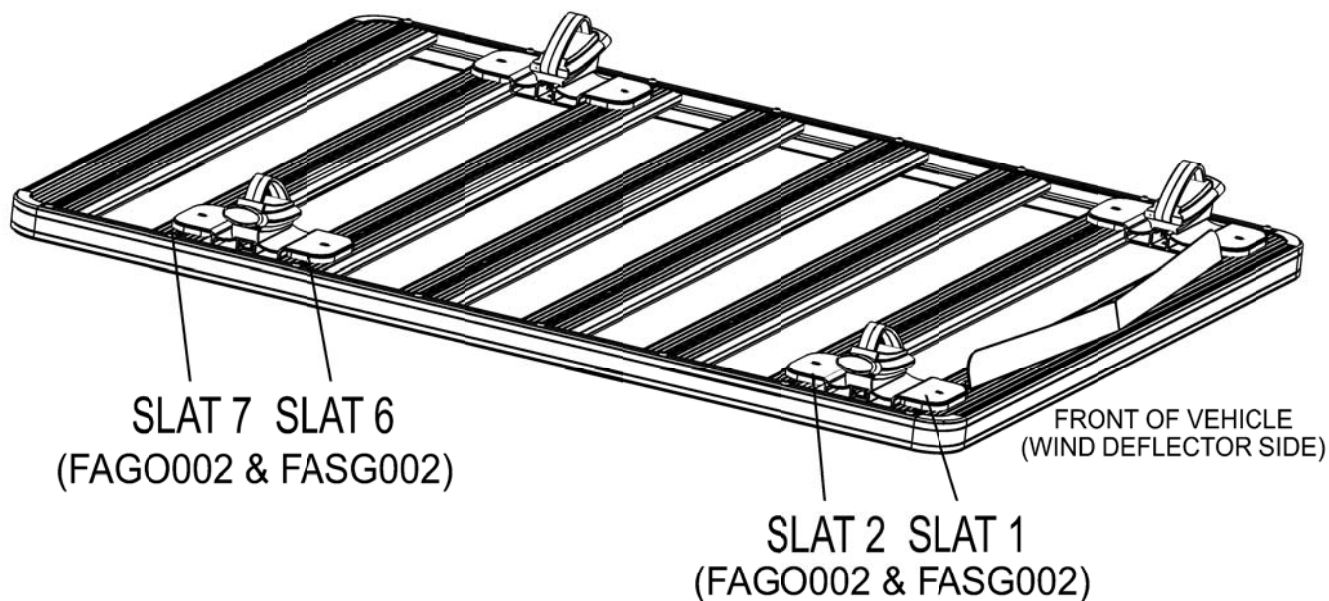

**NOTE:** DO NOT SLIDE THE RACK AND STRAP-ON FEET ACROSS THE ROOF! If there is a chance that you are going to set the roof rack on to the roof, place some moving blankets and/or towels over the roof. If you must lower the rack before it is in position, carefully set the Feet on the padded surface.



Once your Slimline II Roof Rack is fitted, ensure a 15mm clearance is maintained between the Wind Deflector and the vehicles roof otherwise damage to the roof may occur. Bend the Wind Deflector by hand if necessary.

### 3 MOUNT RACK TO YOUR VEHICLE

- (A) Unlock and remove the End Caps from the Strap-on Feet. Un-hook/un-clip the Rubber Straps. Place the Rack Assembly over the Vehicle's Top Rails in the desired front to back position.

Re-hook/Re-clip the Rubber Straps making sure they run under and around the Vehicles Top Rails and adjust each Strap-on Foot so that Vehicle's Top Rail sits centered on the Strap-on Foot.

Each End Cap comes with a Hex Key attachment. Using the Hex Key loosely fasten the Allen Bolts indicated by the arrow.

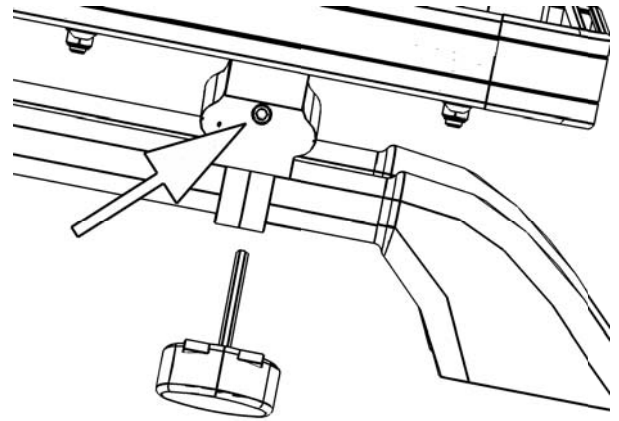

- (B) To complete your installation, center the Rack from left to right using a tape measure. Ensure that the Strap-on Feet are sitting all the way in on the Adapter Plates. Fasten all the M8 Nyloc Nuts securing the Adapter Plates to the Rack and the Allen Bolts on the Strap-on Feet.



### 4 TAKE A TRIP

- (A) After your first adventure, check that all nuts, bolts, screws and fittings are tight. Re-tighten where needed. You'll find a small amount of settling has happened.

Go on many more adventures, periodically checking all nuts, bolts, screws and fittings.



Front Runner can not recommend a maximum load carrying capacity. Please refer to your vehicle manufacturer's recommendations.